

SDPS 2023

TOWARDS A SUPRA-DISCIPLINARY DESIGN AND PROCESS SCIENCE

Workshop Session: Intellectualized Cyber-physical Systems

WHAT WHERE YOU THINKING?

THE NEED FOR EXPLICITLY EXPLICABLE AI SYSTEMS

Position statement by:

Prof. Dr. Duncan Anthony Coulter

Overview

- Agent Orientation
- Multi-Agent Systems
- Artificial Neural Networks
- Embeddings and Latent Spaces
- Evolutionary Algorithms and Latent Spaces



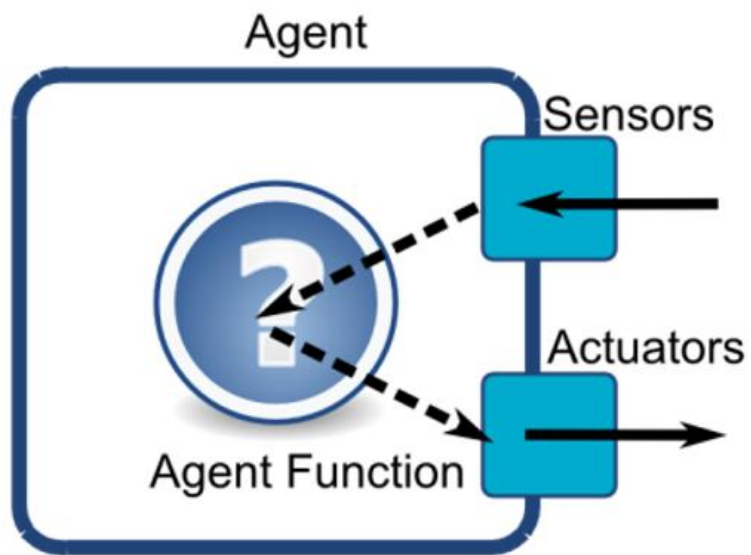

INTELLIGENT
AGENTS AS
BLACK
BOXES

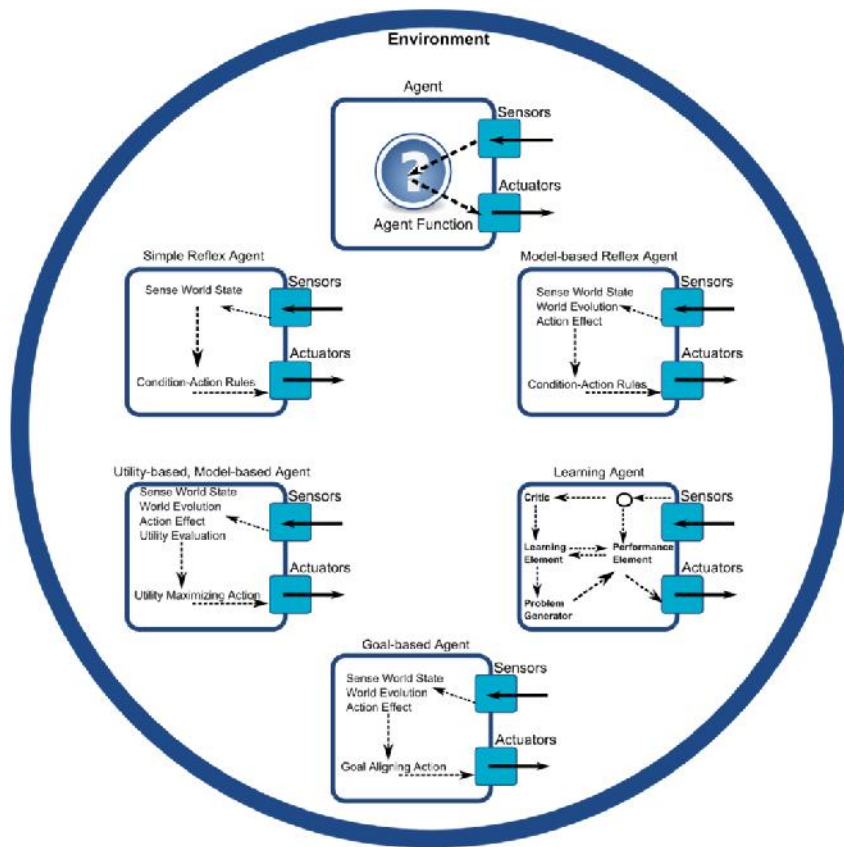

MULTI-AGENT SYSTEMS AS BLACK BOXES

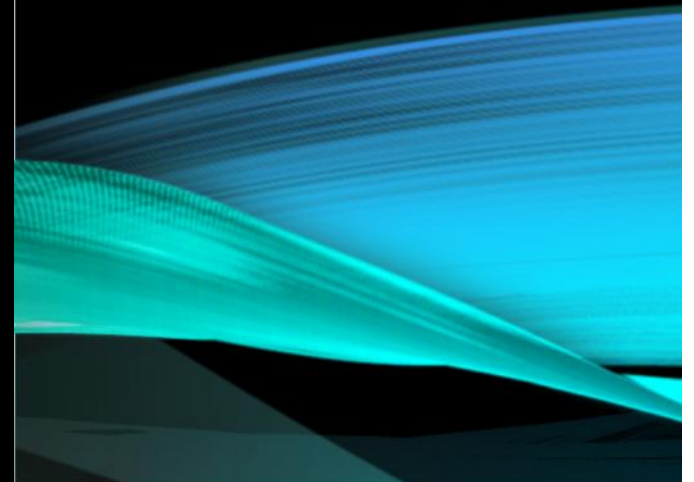

Artificial Neural Networks

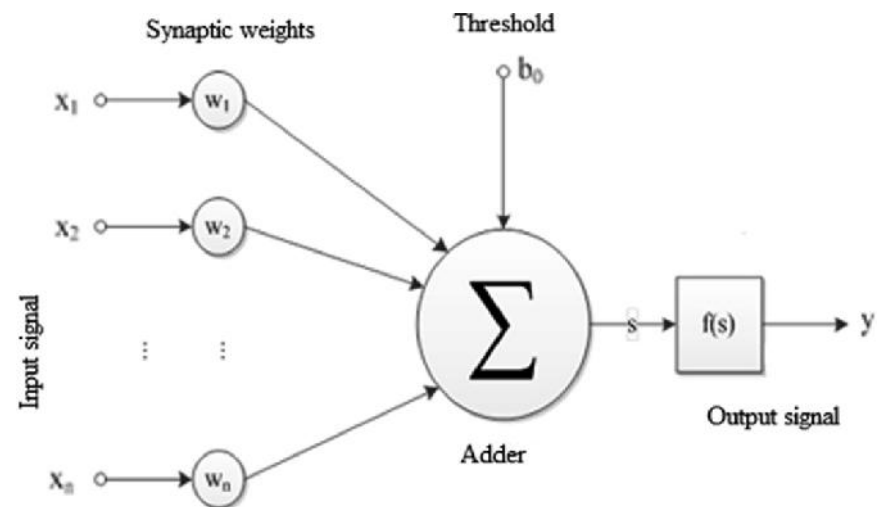

Zgurovsky, M., Sineglazov, V., Chumachenko, E. (2021). Classification and Analysis Topologies Known Artificial Neurons and Neural Networks. In: Artificial Intelligence Systems Based on Hybrid Neural Networks. Studies in Computational Intelligence, vol 904. Springer, Cham. https://doi.org/10.1007/978-3-030-48453-8_1

Artificial Neural Networks

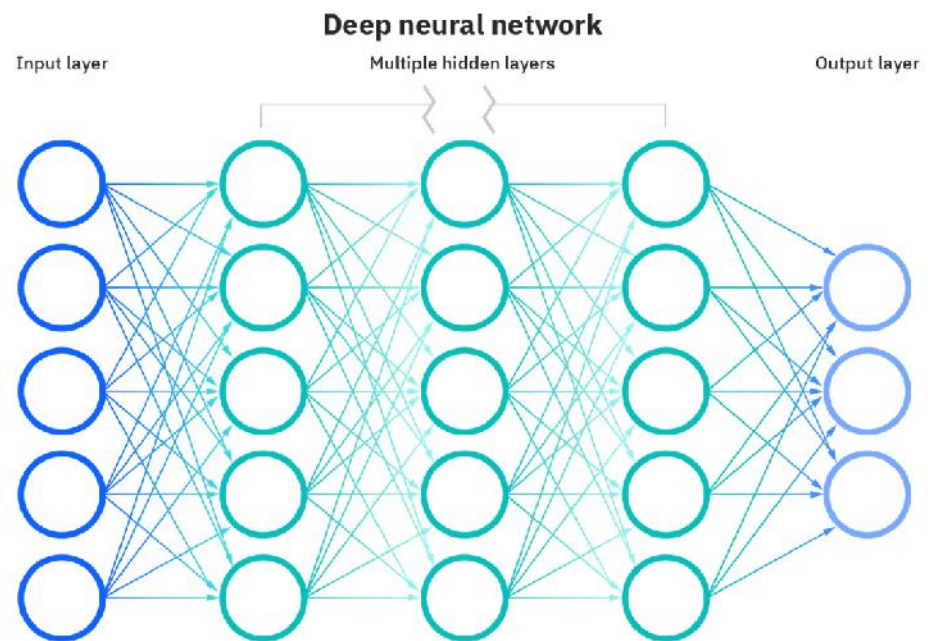

Artificial Neural Networks

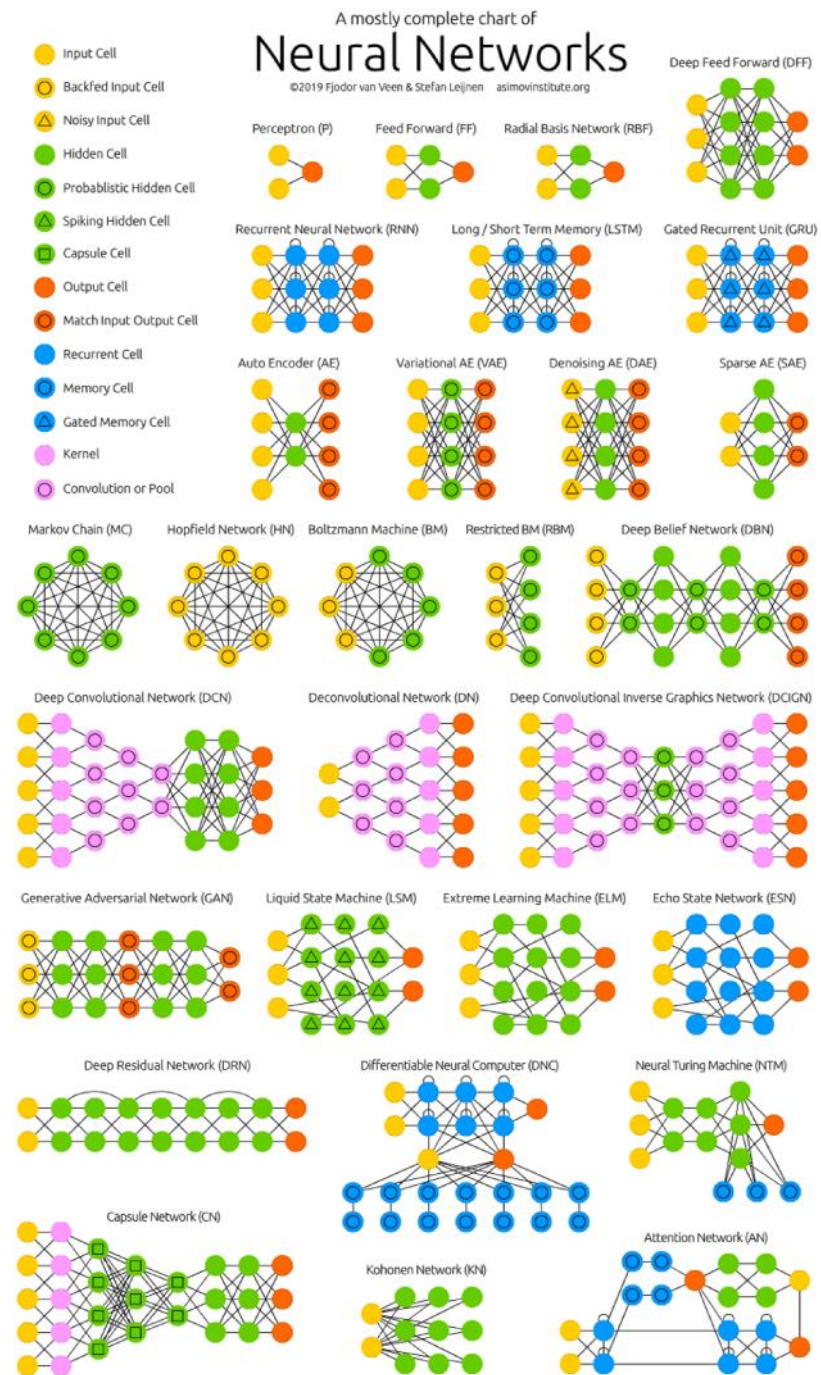

Artificial Neural Networks

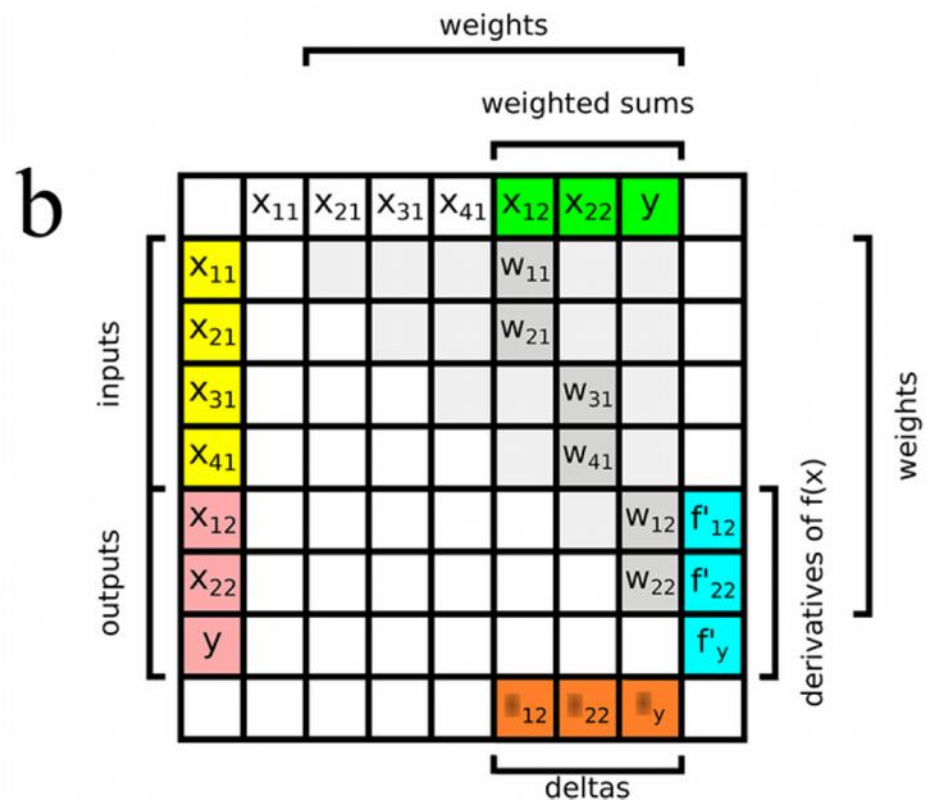
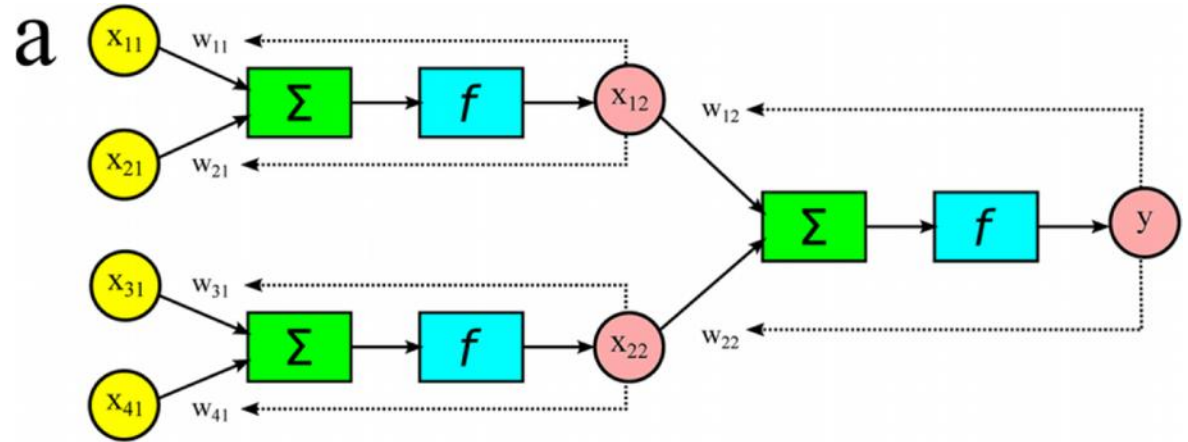

Distributed Artificial Neural Networks

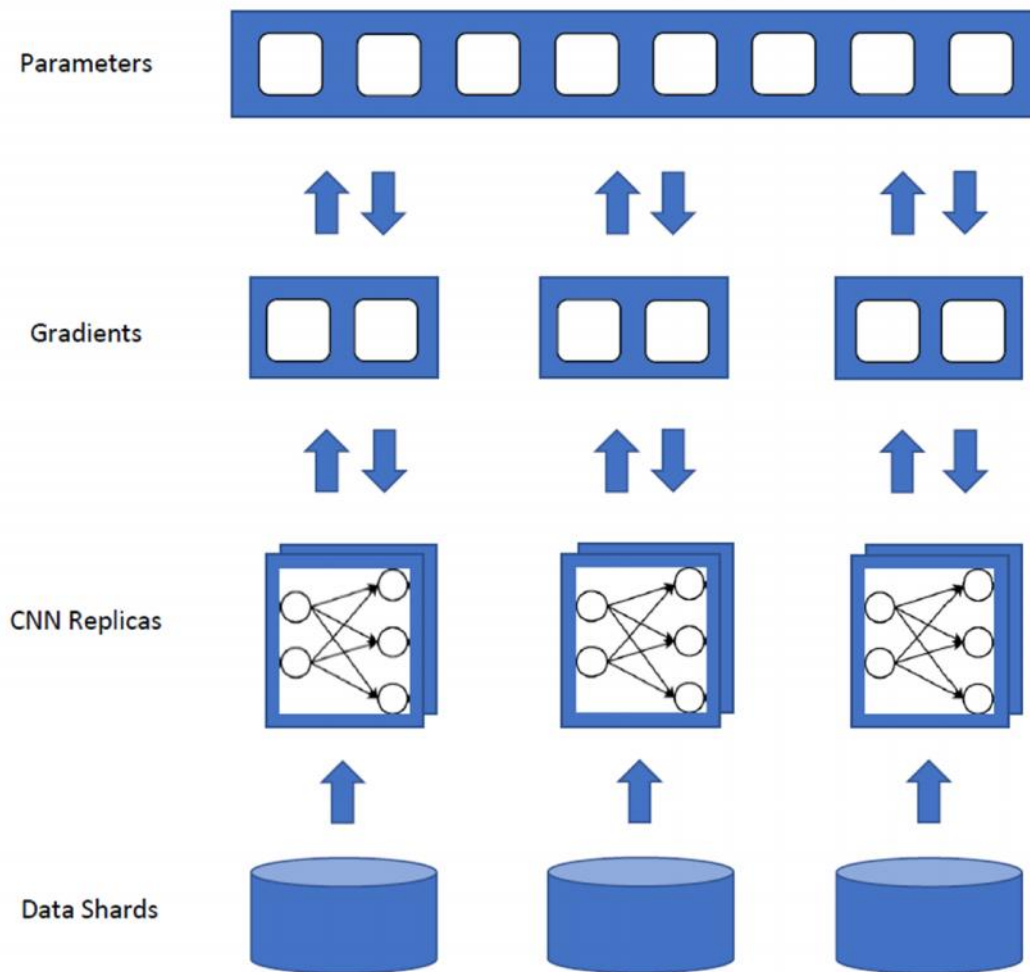

Agent / Actor Oriented Artificial Neural Networks

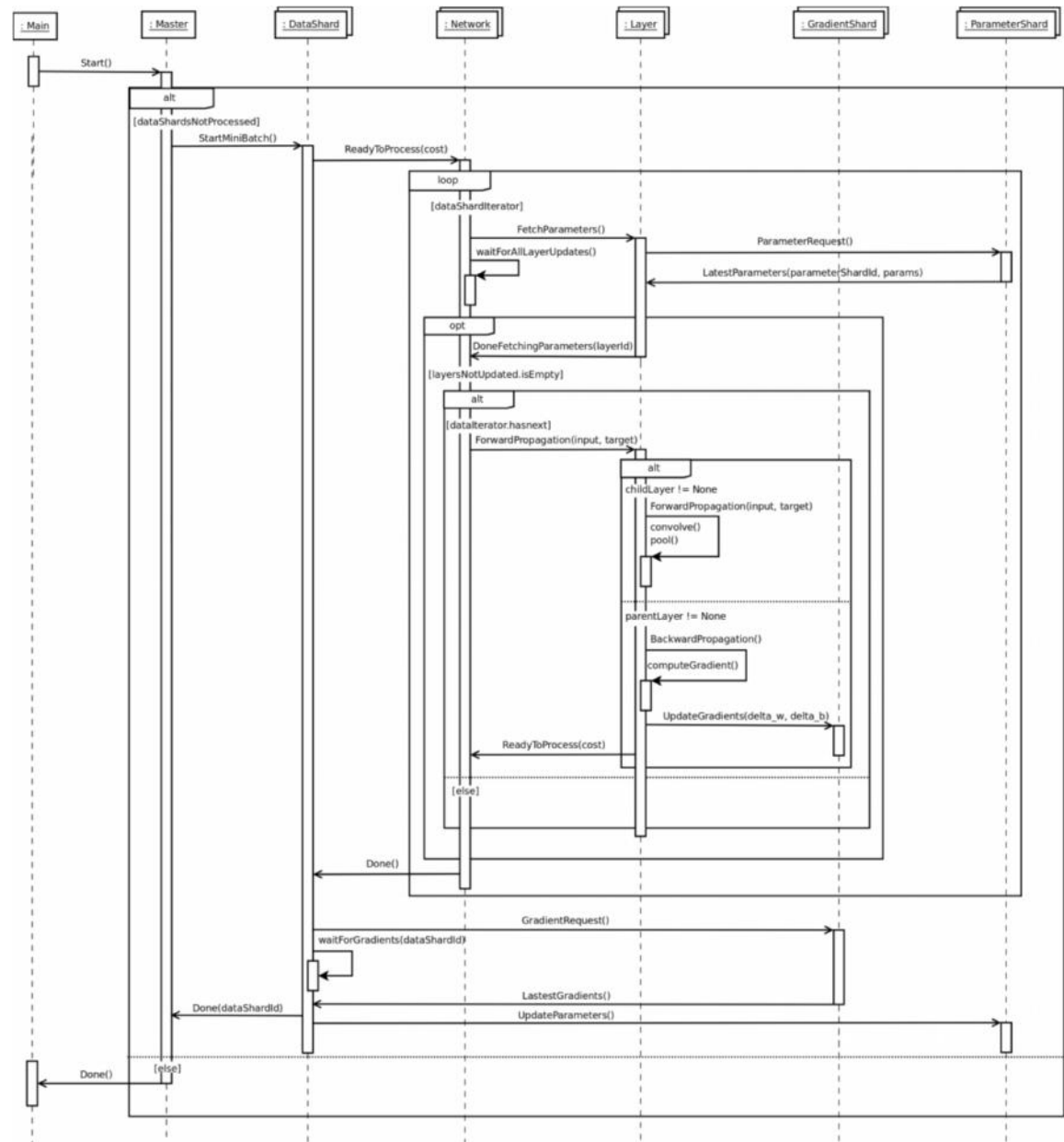

Revisiting the society of mind : convolutional neural networks via multi-agent systems (Cullinan, 2018)

Agent / Actor Oriented Artificial Neural Networks

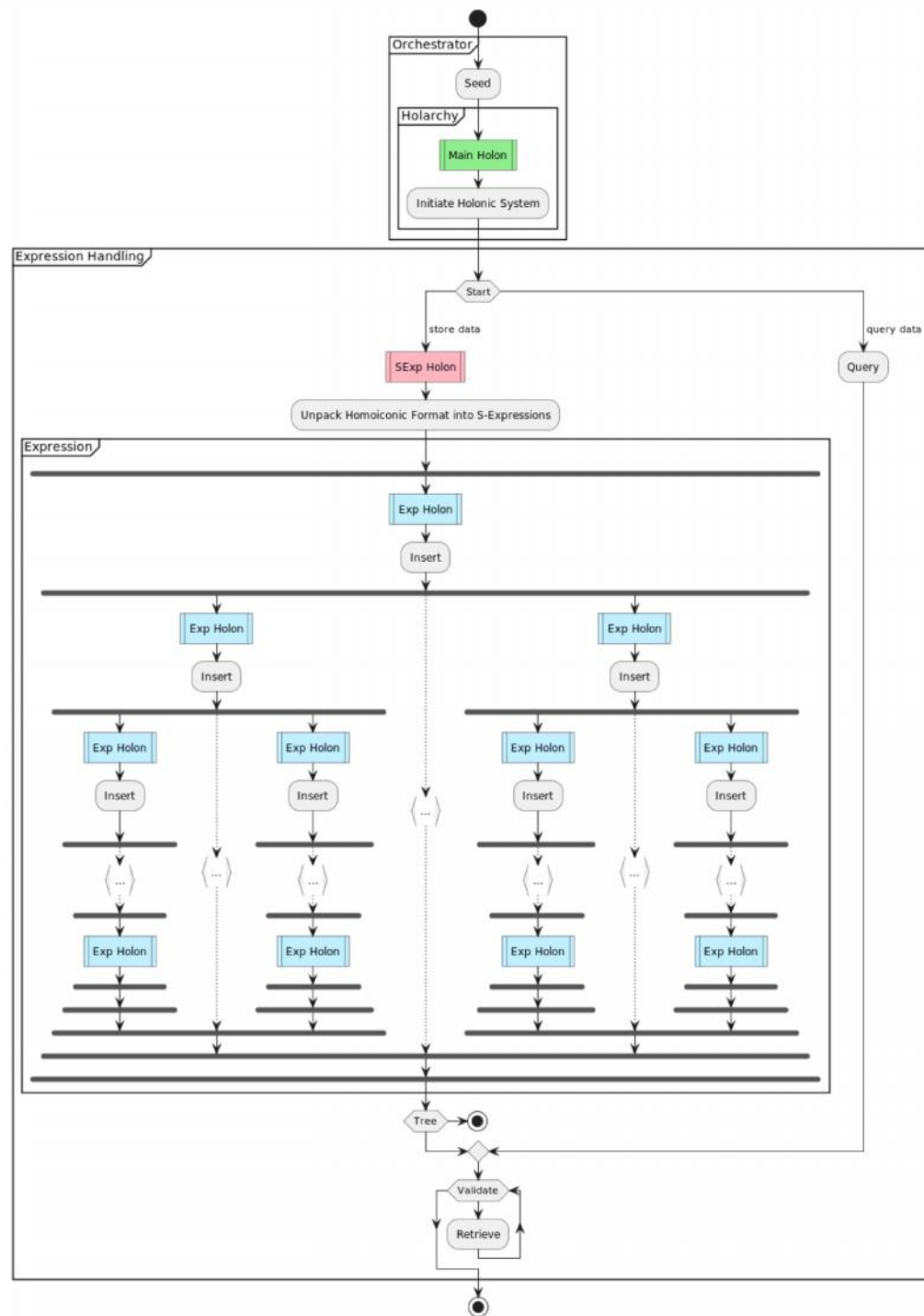

Agent / Actor Oriented Artificial Neural Networks

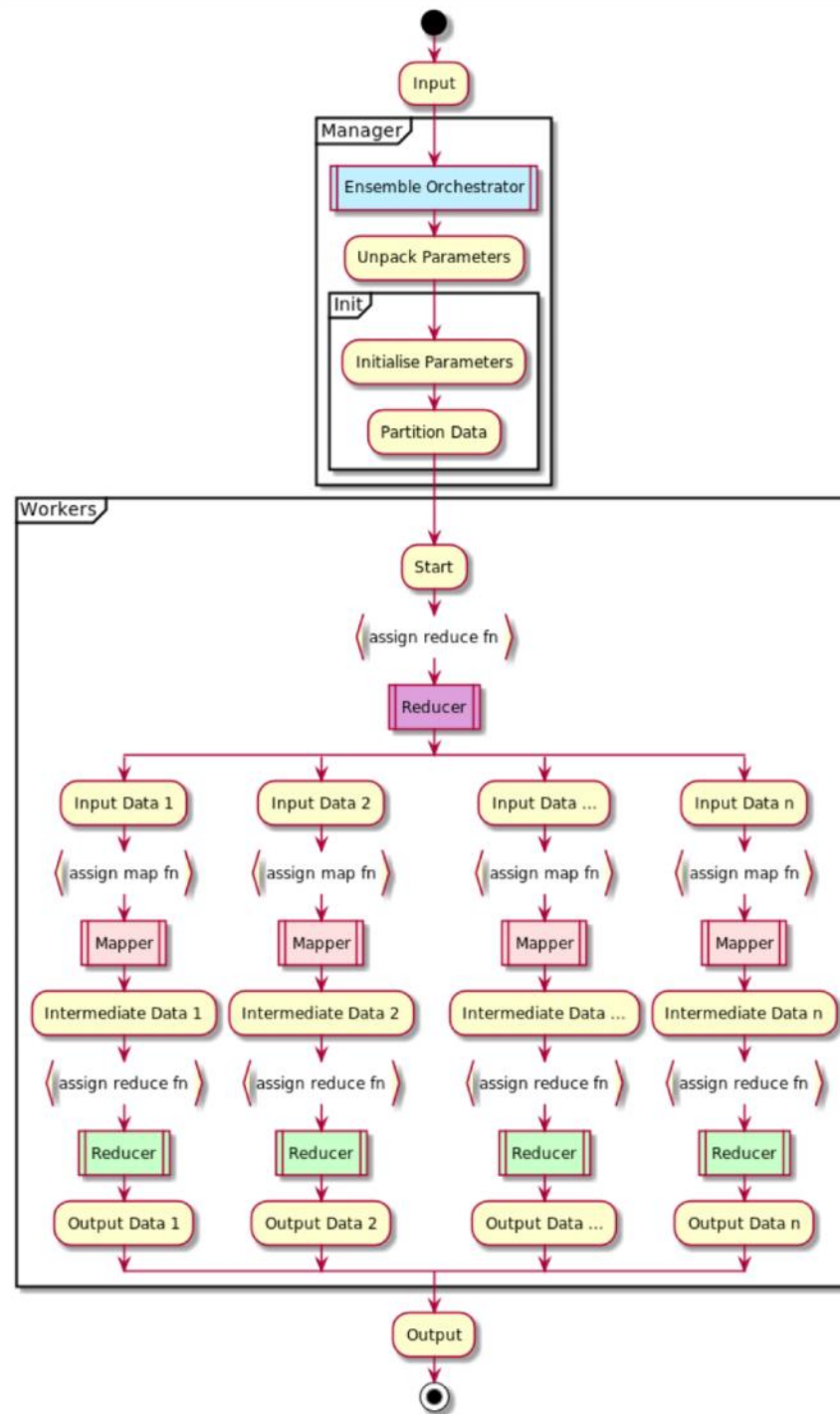

AGENT / ACTOR ORIENTED ARTIFICIAL NEURAL NETWORKS

- COLD SNAP:
Coordination Lattice
Definition via Swarm
based Neighboring Actor
Phase Transitions
(Thomas & Coulter,
2021)
- Actor-Oriented Self-
Organizing Maps (Thomas &
Coulter, 2022)

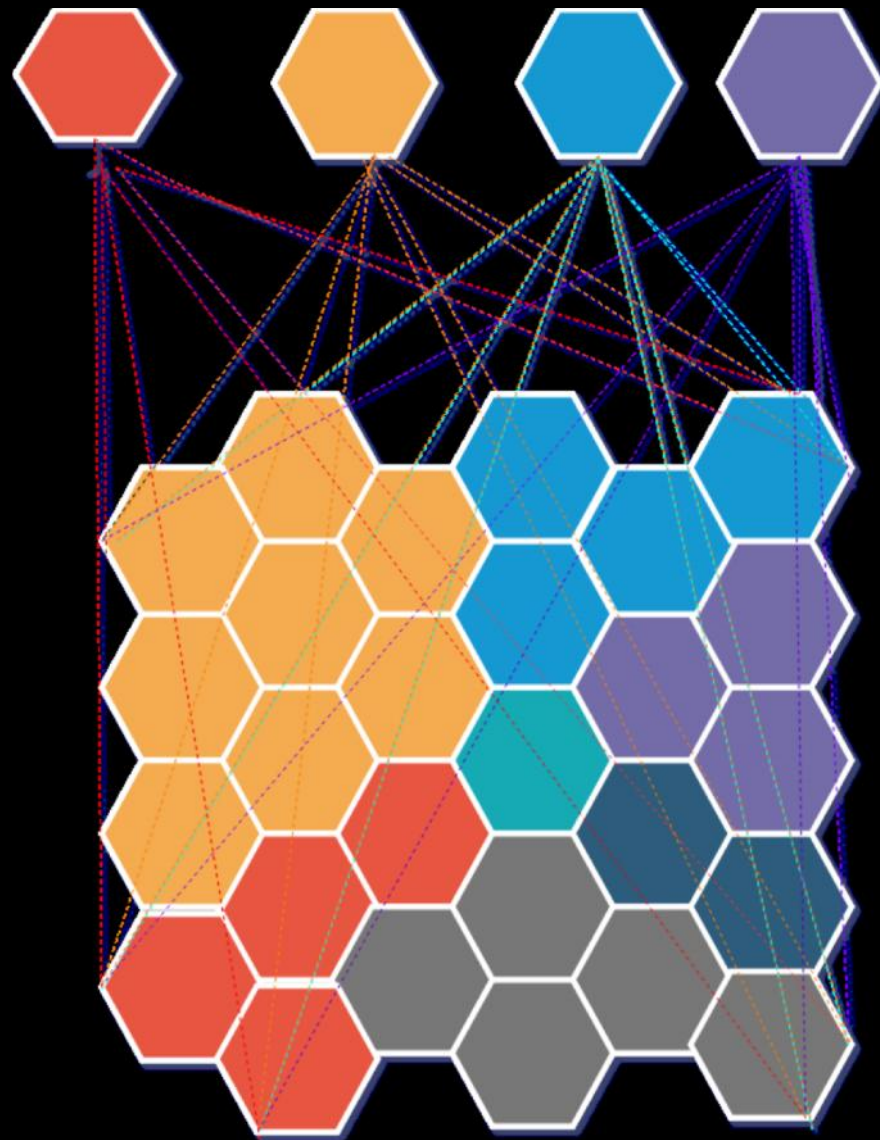

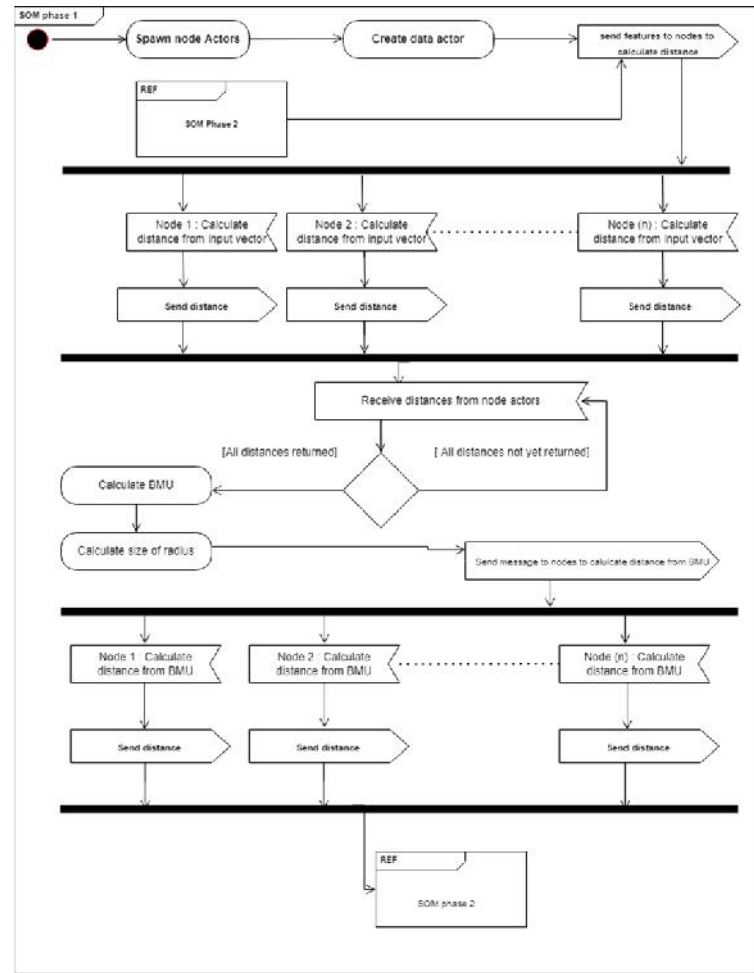
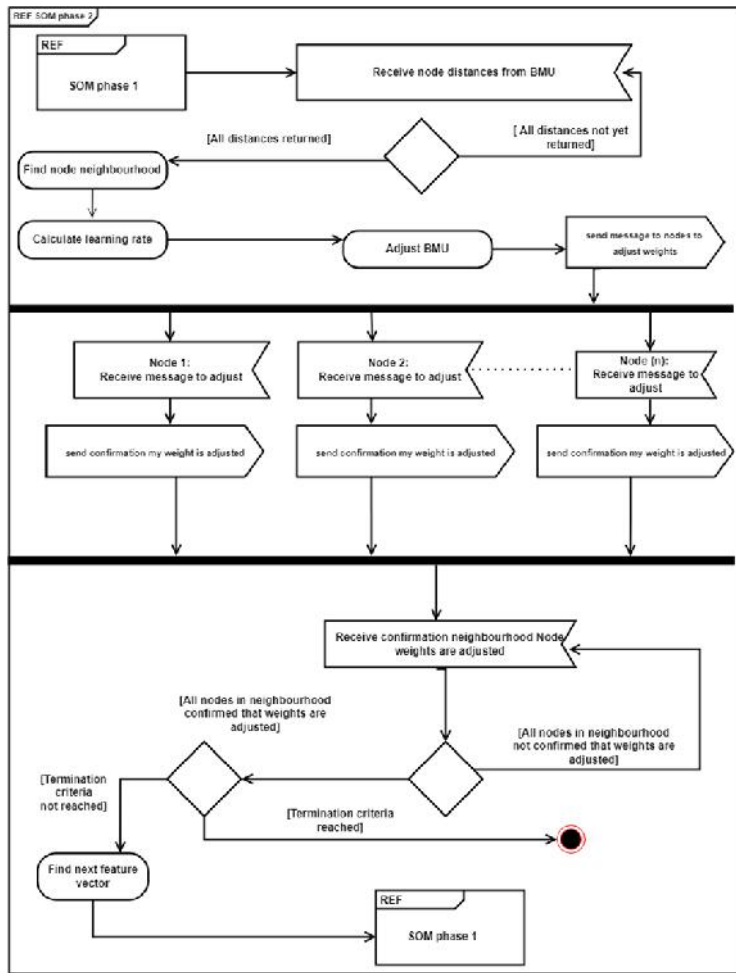

Thomas, P. C., & Coulter, D. A. (2022). Actor-Oriented Self-Organizing Maps: A novel distributed design for Self-Organizing Systems. Proceedings of the 10th International Conference on Computer and Communications Management, 109–117

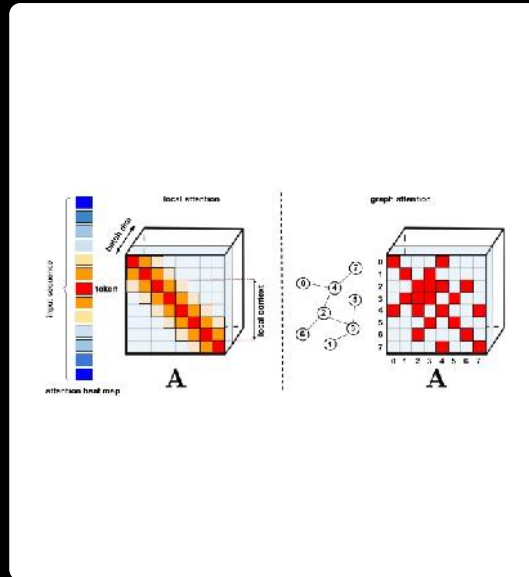
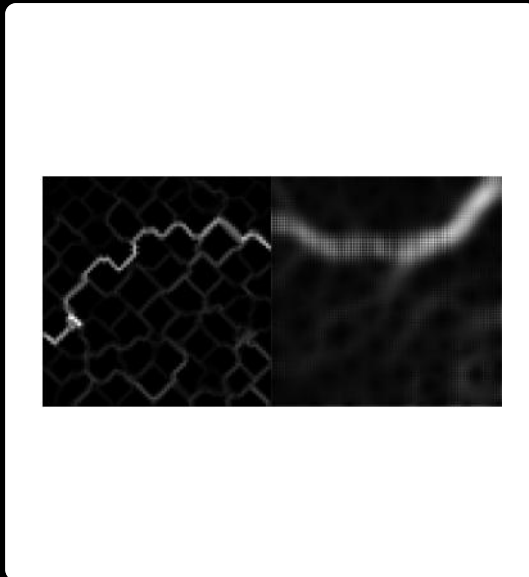
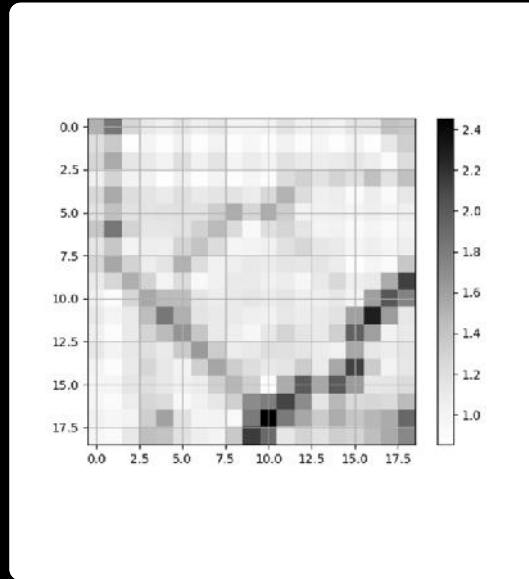
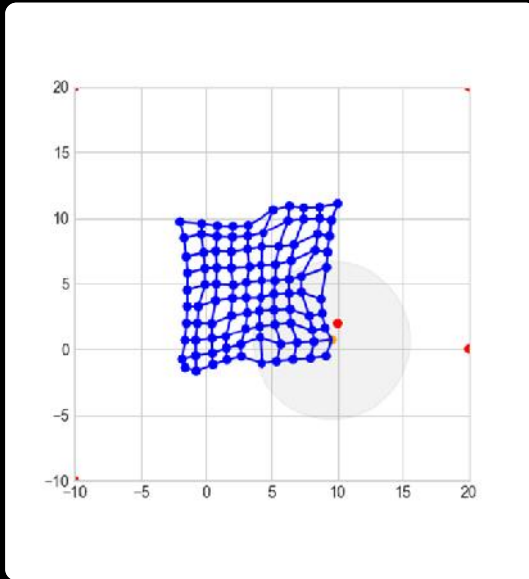

VISUALIZING ARTIFICIAL NEURAL NETWORKS

Kolenic, A. B., & Coulter, D. A. (2022). High Rank Self-Organising Maps for Image Fingerprinting. Artificial Intelligence Applications and Innovations: 18th IFIP WG 12.5 International Conference, AIAI 2022, Hersonissos, Crete, Greece, June 17–20, 2022, Proceedings, Part II, 472–483.

<https://ai.googleblog.com/2020/10/rethinking-attention-with-performers.html>

Vector Embeddings and Latent Spaces

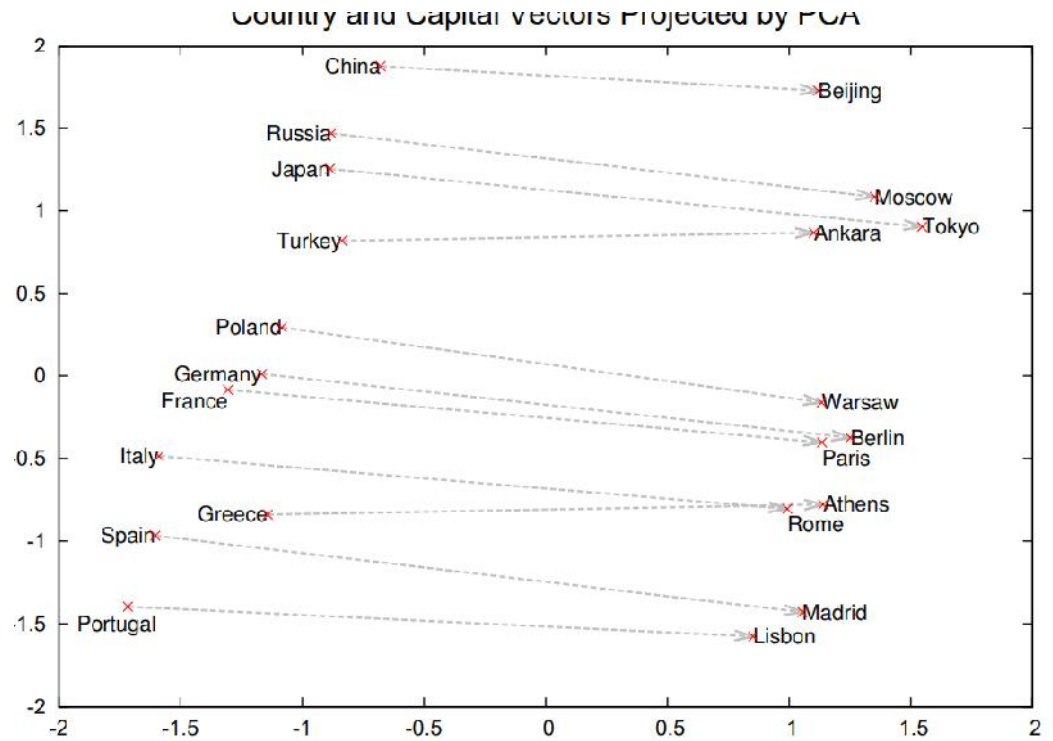

Mikolov, T., Sutskever, I., Chen, K., Corrado, G., & Dean, J. (2013). Distributed Representations of Words and Phrases and their Compositionality. arXiv. <https://doi.org/10.48550/ARXIV.1310.4546>

Manoj, N. (2018). On the Geometry of the Latent Space of Deep Generative Models.

Vectors in latent space mapping to different modes for 2D-Grid (grid length 5)

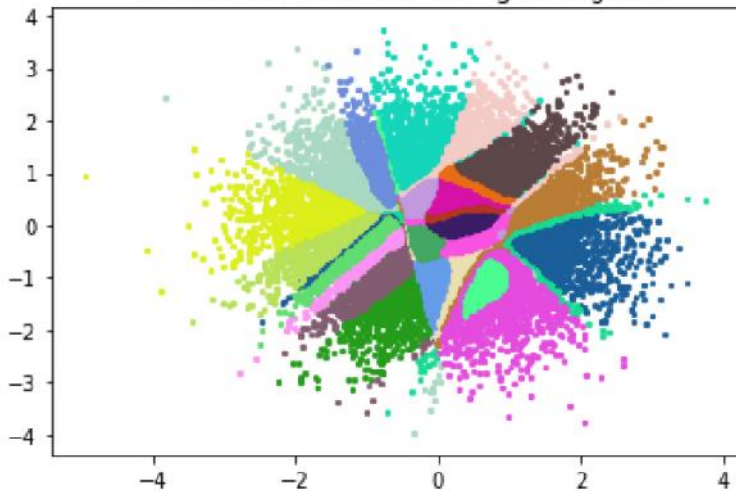

2D Grid of samples obtained. Grid length = 5

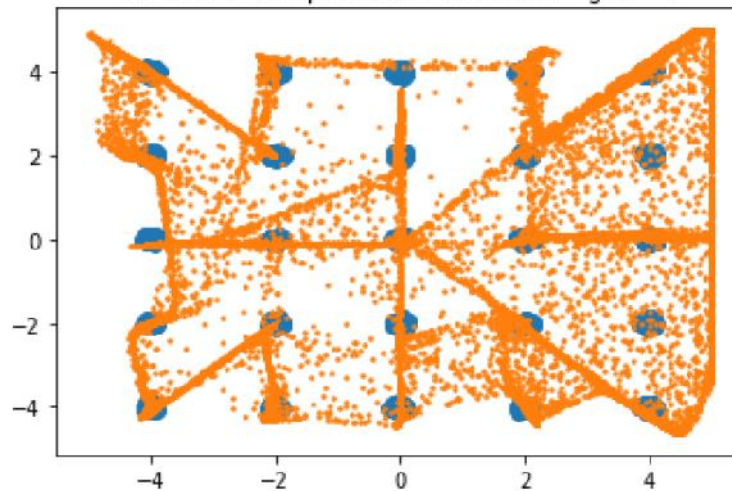

Evolutionary Algorithms and Symbolic Regression

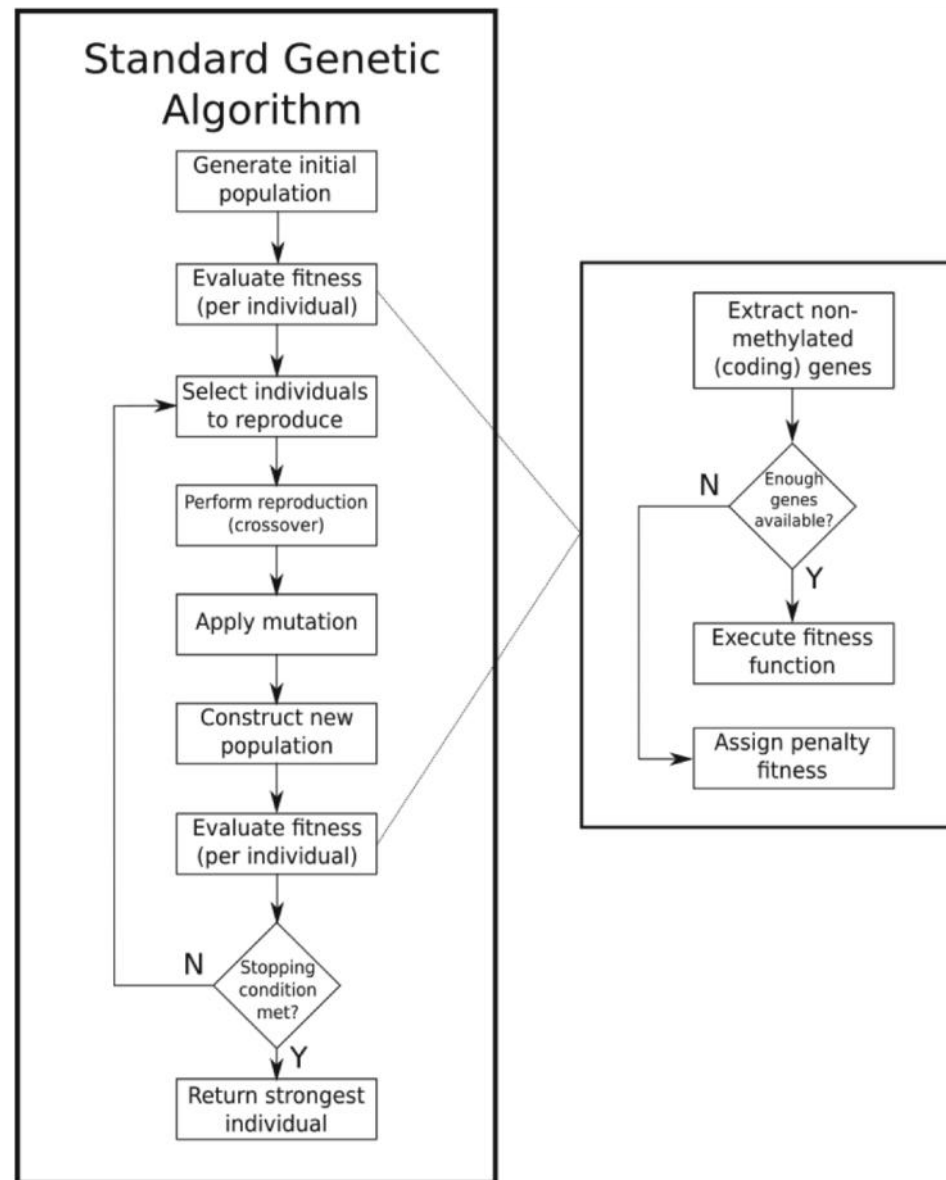

Cilliers, M., & Coulter, D. A. (2019). Improving population diversity through gene methylation simulation. *Artificial Intelligence and Soft Computing: 18th International Conference, ICAISC 2019, Zakopane, Poland, June 16–20, 2019, Proceedings, Part I* 18, 469–480

Evolutionary Algorithms and Symbolic Regression

Parent 1:

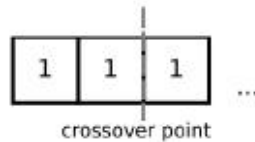

Parent 2:

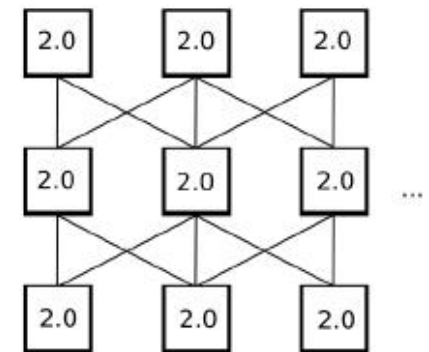
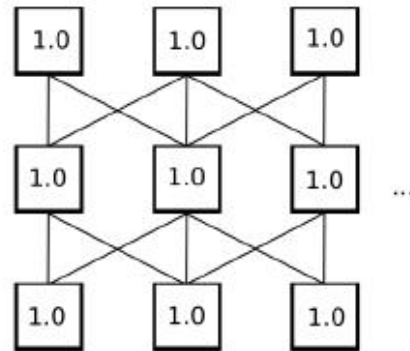
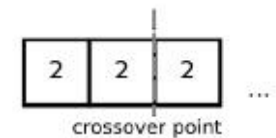

Child 1:

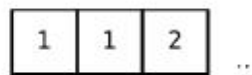

Child 2:

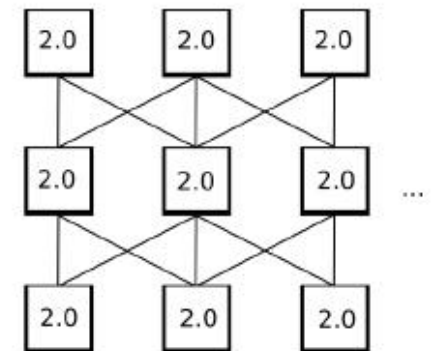
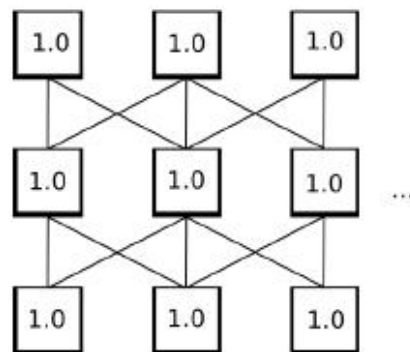
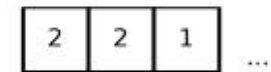

Evolutionary Algorithms and Symbolic Regression

Adapted from Ferreira, C. (2001). "Gene Expression Programming: A New Adaptive Algorithm for Solving Problems" (PDF). Complex Systems, Vol. 13, issue 2: 87-129.

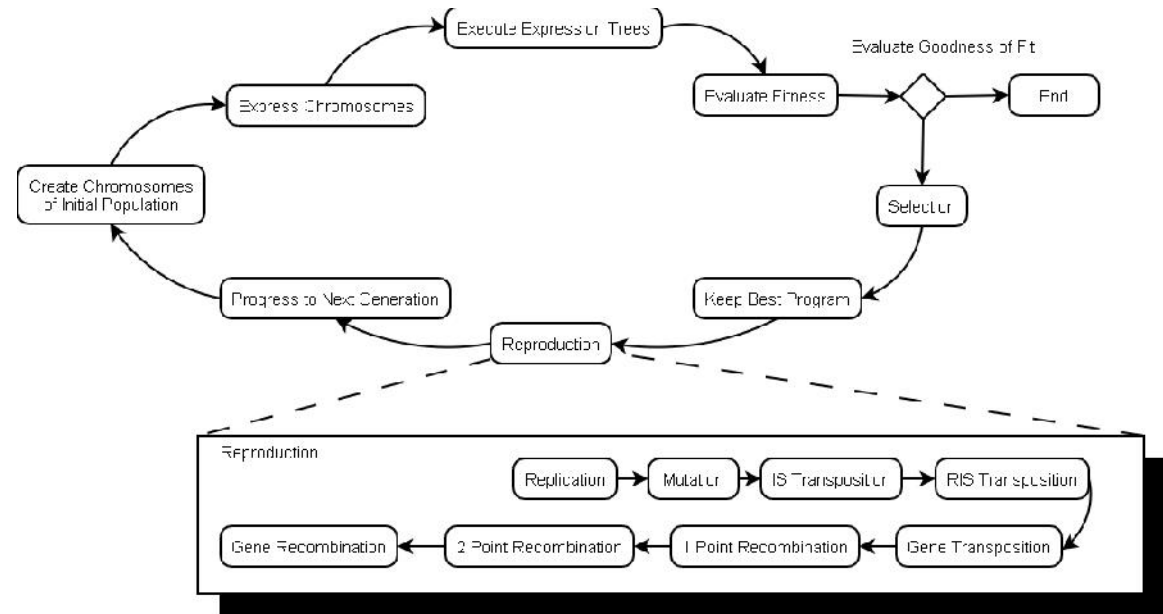

The Anatomy of Genome

0	1	2	3	4	5	6	7
÷	+	-	5	4	π	2	10

GEP solutions are represented as K-Expressions in the Karva language. These represent Open Reading Frames (ORFs) which divide the gene into a coding **head** and non-coding **tail** region according to the following formula (h is the head length, n represents the greatest legal function parameter list length): $t = h(n - 1) + 1$

